



## Actuators

## SQN3... SQN4...

Electromotoric actuators for use with air dampers and control valves of oil or gas burners of small to medium capacity.

The SQN3... / SQN4... and this Data Sheet are intended for use by OEMs which integrate the actuators in their products!

### Use / features

The SQN3... / SQN4... actuators are designed to drive gas and air dampers on small to medium-capacity oil or gas burners or for the load-dependent control of fuel and combustion air volume:

- In connection with P-PI or PID controllers, such as the RWF...
  - Directly via the different types of burner controls, such as LOA..., LMO..., LMG... or LFL...
  - In connection with 1- or 2-wire control or 3-position controllers
- All types of actuators with:
    - Impact-proof and heat-resistant plastic housing
    - Screw terminals for the electrical connections
    - Maintenance-free gear train, which can be disengaged
    - Internal and external position indication
    - Easy-to-adjust end and auxiliary switches for setting the switching points
  - Holding torque:
 

- SQN3...	0.8...3 Nm
- SQN4...	6 Nm
  - Running time:
 

- SQN3...	4.5...30 s
- SQN4...	120 s
  - Direction of rotation:
 

- SQN30...	counterclockwise
- SQN31... / SQN41...	clockwise

## Warning notes

---



**To avoid injury to persons, damage to property or the environment, the following warning notes must be observed!**

### **Do not interfere with or modify the actuators!**

- All activities (mounting, installation and service work, etc.) must be performed by qualified staff
- Before making any wiring changes in the connection area of the actuators, completely isolate the equipment from the mains supply (all-polar disconnection). **Ensure that the plant cannot be inadvertently switched on again and that it is indeed dead. If not observed, there is a risk of electric shock hazard**
- Ensure protection against electric shock hazard by providing adequate protection for the connection terminals and by securing the housing cover
- Each time work has been carried out (mounting, installation, service work, etc.), check to ensure that wiring is in an orderly state
- Fall or shock can adversely affect the safety functions. Such actuators must not be put into operation, even if they do not exhibit any damage

## Mounting notes

---

- Ensure that the relevant national safety regulations are complied with

## Standards and certificates

---



CE conformity according to the directives of the European Union

- Electromagnetic compatibility EMC
- Low-voltage directive

2004/108/EC  
2006/95/EC



ISO 9001: 2008  
Cert. 00739



ISO 14001: 2004  
Cert. 38233

## Disposal notes

---



The actuator contains electrical and electronic components and must not be disposed of together with domestic waste.  
Local and currently valid legislation must be observed.

## Mechanical design

---

- Housing
- Made of impact-proof and heat-resistant plastic
  - The housing accommodates:
    - The reversible synchronous motor with gear train, which can be **disengaged**
    - The camshaft of the control section
    - The relays (depending on the type of actuator)
    - The switches, connected to the terminals via the printed circuit board

Color: Gear train housing light-grey, cover dark-grey

- Drive motor
- Reversible and locking-proof synchronous motor

- Coupling
- Shaft can be disengaged from gear train and motor via manual operation of a coupler pressure pin «K»
  - Automatic reengagement

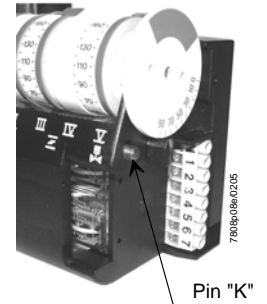

- Adjustment of switching points
- With adjustable cams
  - Scales beside the cams indicate the angle of the switching point
  - The other cams can be adjusted manually or with the enclosed hook-spanner or similar tool

- Position indication
- Internally: Scale on the gear train side of the camshaft
  - Externally: Scale in viewing window (refer to «Dimensions»)

- Electrical connections
- Refer to «Technical data»

- Gear train
- Maintenance-free

- Drive shaft
- Made of black-finished steel.
  - Ready fitted to the front of the gear train
  - Different versions available

- Mounting and fixing
- Front of the gear train is used as the mounting surface
  - Actuator is secured via through-holes

## Special versions for fitting potentiometer

---

Fitting a potentiometer

Certain types of actuators are supplied ready prepared for fitting a potentiometer. These actuators differ from the basic type **only in that the housing is higher** and that they are prepared for accommodating a potentiometer. Accessories are not required. The required type of potentiometer is to be ordered as a separate item (refer to «Ordering»). In that case, the third digit after the dot in the actuator's type reference will change from «1» to «2».

Example:

SQN31.111A2700 → basic type

SQN31.112A2700 → version for fitting a potentiometer

Conversion by the user

Users have the choice of converting a basic type of actuator to a version for fitting a potentiometer. For that, a conversion kit type **AGA32** is available (refer to «Ordering»).



### Attention!

Conversion of the basic type reference must be noted by the user on the actuator's type field using a permanent felt-tip pen.

**Type summary** (others types of actuators are available on request)

**Actuators SQN30... / counterclockwise rotation <sup>8)</sup>**

Diagram no.	Drive shaft <sup>1)</sup> no.	Running time at 50 Hz <sup>2)</sup> for 90° s	Operating torque (max.) Nm	Holding torque Nm	HS <sup>7)</sup> pcs.	Relay pcs.	Housing length <sup>1)</sup> mm	Types for mains voltage / mains frequency	
								AC 220 V -15 % AC 240 V +10 % 50...60 Hz <sup>4)</sup>	AC 100 V -15 % AC 110 V +10 % 50...60 Hz <sup>3)</sup>
0	0	4.5	1	0.8	3	---	125	<b>SQN30.102A2700</b> <sup>5)</sup>	---
1	0	4.5	1	0.8	2	1	110	<b>SQN30.111A2700</b>	<b>SQN30.111A1700</b>
1	0	4.5	1.5	0.8	2	1	110	<b>SQN30.111A3500</b> <sup>9)</sup>	---
2	0	4.5	1	0.8	1	2	110	<b>SQN30.121A2700</b>	<b>SQN30.121A1700</b>
2	0	4.5	1.5	0.8	1	2	110	<b>SQN30.121A3500</b> <sup>9)</sup>	---
3	0	4.5	1	0.8	1	2	110	<b>SQN30.131A2700</b>	<b>SQN30.131A1700</b>
5	0	4.5	1	0.8	1	2	110	<b>SQN30.151A2700</b>	<b>SQN30.151A1700</b>
5	0	12	1.8	1.8	1	2	110	<b>SQN30.251A2700</b>	<b>SQN30.251A1700</b>
0	0	30	3	3	3	---	110	<b>SQN30.401A2700</b>	---
0	3	30	3	3	3	---	110	<b>SQN30.401A2730</b>	---
0	0	30	3	3	3	---	125	<b>SQN30.402A2700</b> <sup>5)</sup>	<b>SQN30.402A1700</b> <sup>5)</sup>
0	3	30	3	3	3	---	125	<b>SQN30.402A2730</b> <sup>5)</sup>	---
1	0	30	3	3	2	1	110	<b>SQN30.411A2700</b>	---
3	0	30	3	3	1	2	110	<b>SQN30.431A2700</b>	---
5	0	30	3	3	1	2	110	<b>SQN30.451A2700</b>	---

**Actuators SQN31... / clockwise rotation <sup>8)</sup>**

Diagram no.	Drive shaft <sup>1)</sup> no.	Running time at 50 Hz <sup>2)</sup> for 90° s	Operating torque (max.) Nm	Holding torque Nm	HS <sup>7)</sup> pcs.	Relay pcs.	Housing length <sup>1)</sup> mm	Types for mains voltage / mains frequency	
								AC 220 V -15 % AC 240 V +10 % 50...60 Hz <sup>4)</sup>	AC 100 V -15 % AC 110 V +10 % 50...60 Hz <sup>3)</sup>
0	0	4.5	1	0.8	3	---	110	<b>SQN31.101A2700</b>	<b>SQN31.101A1700</b>
0	0	4.5	1	0.8	3	---	125	<b>SQN31.102A2700</b> <sup>5)</sup>	<b>SQN31.102A1700</b> <sup>5)</sup>
1	0	4.5	1	0.8	2	1	110	<b>SQN31.111A2700</b>	---
1	6	4.5	1	0.8	2	1	110	<b>SQN31.111A2760</b>	---
2	0	4.5	1	0.8	1	2	110	<b>SQN31.121A2700</b>	---
2	3	4.5	1	0.8	1	2	110	<b>SQN31.121A2730</b>	---
2	6	4.5	1	0.8	1	2	110	<b>SQN31.121A2760</b>	---
5	0	4.5	1	0.8	1	2	110	<b>SQN31.151A2700</b>	<b>SQN31.151A1700</b>
5	3	4.5	1	0.8	1	2	110	<b>SQN31.151A2730</b>	---
2	0	12	1.8	1.8	1	2	110	<b>SQN31.221A2700</b>	---
2	3	12	1.8	1.8	1	2	110	<b>SQN31.221A2730</b>	---
5	0	12	1.8	1.8	1	2	110	<b>SQN31.251A2700</b>	<b>SQN31.251A1700</b>
5	3	12	1.8	1.8	1	2	110	<b>SQN31.251A2730</b>	---
0	0	12	1.8	1.8	3	---	125	<b>SQN31.202A2700</b> <sup>5)</sup>	---
5	0	12	1.8	1.8	1	2	125	<b>SQN31.252A2700</b> <sup>5)</sup>	<b>SQN31.252A1700</b> <sup>5)</sup>
5	0	15	2	1.8	1	2	110	<b>SQN31.351A2700</b>	---
0	0	30	3	3	3	---	110	<b>SQN31.401A2700</b>	<b>SQN31.401A1700</b>
0	3	30	3	3	3	---	110	<b>SQN31.401A2730</b>	---
0	6	30	3	3	3	---	110	<b>SQN31.401A2760</b>	---
0	0	30	3	3	3	---	125	<b>SQN31.402A2700</b> <sup>5)</sup>	<b>SQN31.402A1700</b> <sup>5)</sup>
1	0	30	3	3	2	1	110	<b>SQN31.411A2700</b>	---
1	3	30	3	3	2	1	110	<b>SQN31.411A2730</b>	---
6	0	23	2.5	2.5	---	2	125	<b>SQN31.762A2700</b> <sup>5)</sup>	---
4	0	120	6	6	2	1	110	<b>SQN31.941A2700</b>	---

**Type summary** (others types of actuators are available on request) (cont'd)

**Actuators SQN41... / clockwise rotation <sup>8)</sup>**

Diagram no.	Drive shaft <sup>1)</sup> no.	Running time at 50 Hz <sup>2)</sup> for 90°	Operating torque (max.) Nm	Holding torque Nm	HS <sup>7)</sup> pcs.	Relay pcs.	Housing length <sup>1)</sup> mm	Types for mains voltage / mains frequency	
								AC 220 V -15 % AC 240 V +10 % 50...60 Hz <sup>4)</sup>	AC 100 V -15 % AC 110 V +10 % 50...60 Hz <sup>3)</sup>
4	0	120	6	6	2	1	110	<b>SQN41.941A2700</b>	---

**Legend**

- 1) Refer to «Dimensions»
- 2) At 60 Hz, running times are about 20 % shorter
- 3) AC 100...110 V +10 % / -15 % possible, but in case of undervoltage torque is reduced by about 20 %
- 4) AC 220...240 V +10 % / -15 % possible, but in case of undervoltage torque is reduced by about 20 %
- 5) Suited for fitting a potentiometer (refer to «Fitting a potentiometer»)
- 6) Under nominal conditions; under extreme conditions (e.g. +60 °C, AC 230 V -15 %) about -25 %
- 7) Optional auxiliary switches (in addition to the 2 end switches)
- 8) When facing the drive shaft and when control voltage is fed to end switch I
- 9) On time at:
  - AC 220 V -15 % / +10 % and 50 Hz – max. 50 %
  - AC 240 V -15 % / +10 % and 50 Hz – max. 35 %

**Ordering**

**Actuator** refer to «Type summary»

**Potentiometer ASZ....** refer to Data Sheet N7921



**Conversion kit AGA32** refer to Data Sheet N7921  
 - For converting a basic type of actuator to a version for fitting a potentiometer

Example of conversion by the user:

- SQN30.401A2730 - Actuator (refer to «Type summary»)
- AGA32 - Conversion kit
- ASZ8.703 - Coiled potentiometer 220 Ω / 90°, 3-pole

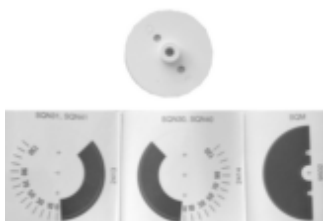

**Service kit AGA33** refer to Data Sheet N7921  
 - For replacing old potentiometers type ASZ...5... / ASZ...6... by new potentiometers type ASZ...7... and ASZ...8...

## Technical data

### General actuator data

#### Actuator

Mains voltage	AC 220...240 V –15 % +10 % AC 100...110 V –15 % +10 %
Mains frequency	50...60 Hz ±6 %
Primary fuse (external)	6.3 AT (customer responsible for installation)
Type of motor	synchronous motor
Power consumption	6.5 VA
Angular position	max. 160°
Mounting position	optional
Degree of protection	IP 40 to DIN 40050, provided adequate cable entries and fixing screws are used
Safety class	I to VDE 0631
Cable entry	threaded cable gland holder for 1 x Pg9 and 1 x Pg11, no locknut required  cable strain relief to be provided by the user (also refer to «Degree of protection»), Pg glands for all types are included in the delivery
Cable connections	screw terminals for wires having a cross-sectional area of 0.5 to 2.5 mm <sup>2</sup>
Ferrules	matching the dia. of the stranded wire
Direction of rotation	refer to «Type summary»
Torques and holding torques	refer to «Type summary»
Running times	refer to «Type summary»
Life cycle	Cycles (CLOSED ⇒ OPEN ⇒ CLOSED) at specified torque: typical 250,000
Weight (on average)	approx. 800 g

#### End and auxiliary switches

Number of end switches	2
Number of auxiliary switches	refer to «Type summary»
Actuation	via camshaft, color-coded cams (refer to «Connection diagrams»)
Switching voltage	AC 24...250 V
Adjustment of cams in increments of	1°
Perm. terminal rating at cosφ = 0,9:	Peak current      Operating current
Electronic circuit	
- under load ON, not under load OFF	Max. 14 A      2 A
- under load ON, under load OFF	Max. 7 A      1 A

#### Environmental conditions

<b>Storage</b>	DIN EN 60 721-3-1
Climatic conditions	class 1K2
Mechanical conditions	class 1M2
Temperature range	-20...+60 °C
Humidity	< 95 % r.h.
<b>Transport</b>	DIN EN 60 721-3-2
Climatic conditions	class 2K2
Mechanical conditions	class 2M2
Temperature range	-20...+60 °C
Humidity	< 95 % r.h.
<b>Operation</b>	DIN EN 60 721-3-3
Climatic conditions	class 3K3
Mechanical conditions	class 3M3
Temperature range	-20...+60 °C
Humidity	< 95 % r.h.



#### Attention!

Condensation, formation of ice and ingress of water are not permitted!

## Function

---

A synchronous motor drives the drive shaft and the camshaft via a gear train. The attached camshaft actuates the end and auxiliary switches. The switching position of each end and auxiliary switch can be adjusted within its working range via the associated cam. Some of the actuator versions are equipped with electronic modules for auxiliary functions in connection with the end and auxiliary switches or with external devices, such as controllers (refer to «Connection diagrams»). The functions and technical data of both lines of actuators SQN3... and SQN4... are nearly identical.



## Connection diagrams



### Note!

The following connection diagrams show the actuator's start position as supplied:  
 - End switch position II (CLOSED)  
 - Dead

No. ① → LFL... / LGK16... / LAL... and LOK16...

2-stage or modulating operation → Prepurging at nominal load position «NL»

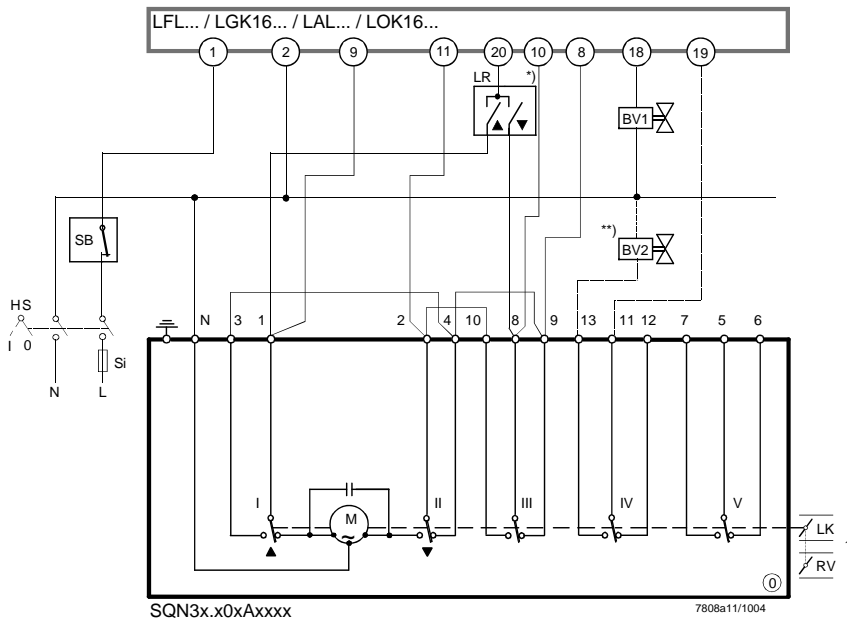

1) Diagram shows arrangement for modulating operation

\*) Thermostat or similar with changeover contact (2-wire control) or 3-position controller for «on / off» positioning pulses and neutral position

\*\*\*) In case of modulating operation, fuel valve «BV2» is replaced by a gas control valve «RV»

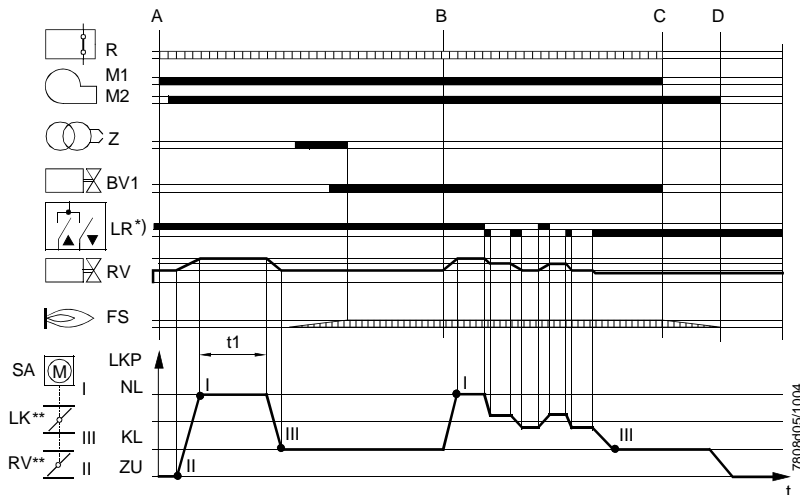

Program sequence diagram shows modulating operation

Connection diagrams (cont'd)

No. ① → LFL... / LGK16... / LAL... / LOK16...

2-stage operation → Prepurging at nominal load position «NL»

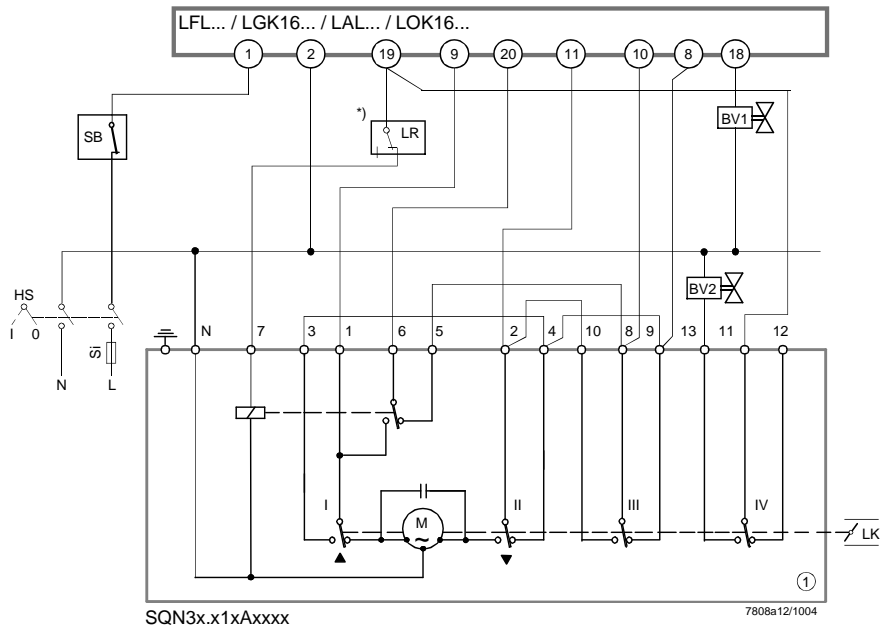

\*) Thermostat or similar with NO contact (1-wire control)

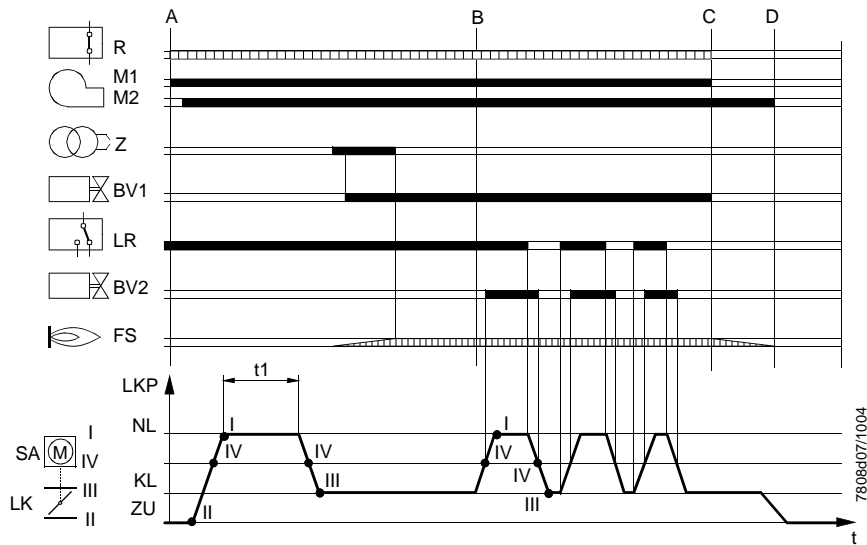

No. ② → LOA24... / LOA25... / LOA28... / LMO24... / LMO44...

2-stage operation → Prepurging at low-fire position «KL»

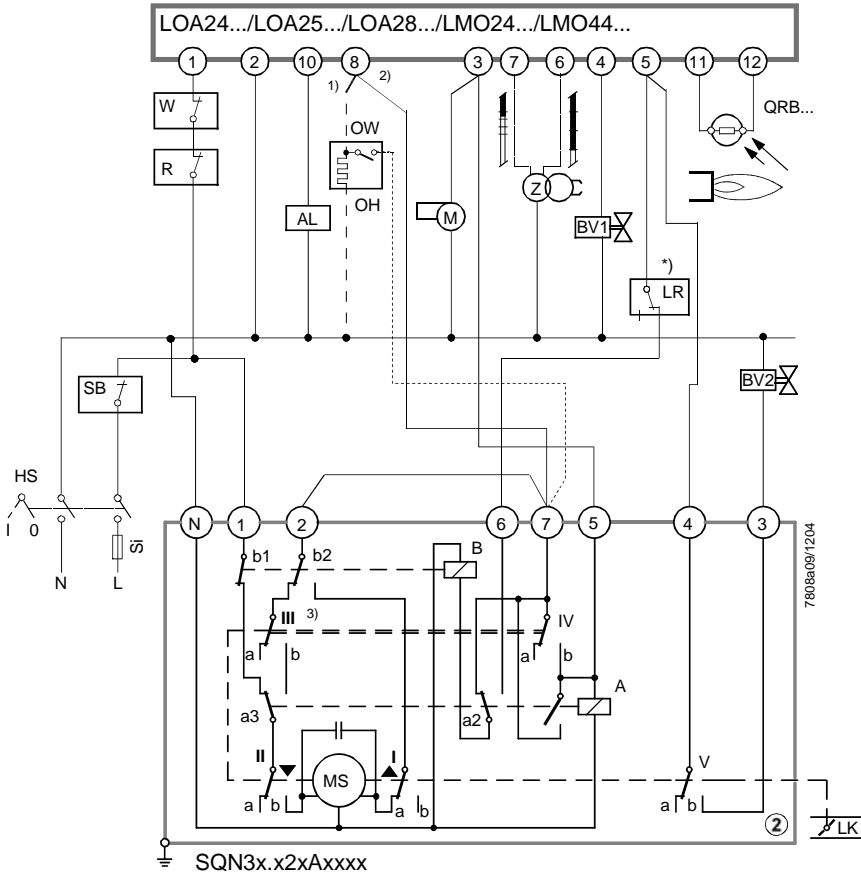

- 1) With oil preheater
- 2) Without oil preheater
- \*) Thermostat or similar with NO contact (1-wire control)
- 3) Cams III and IV are rigidly connected

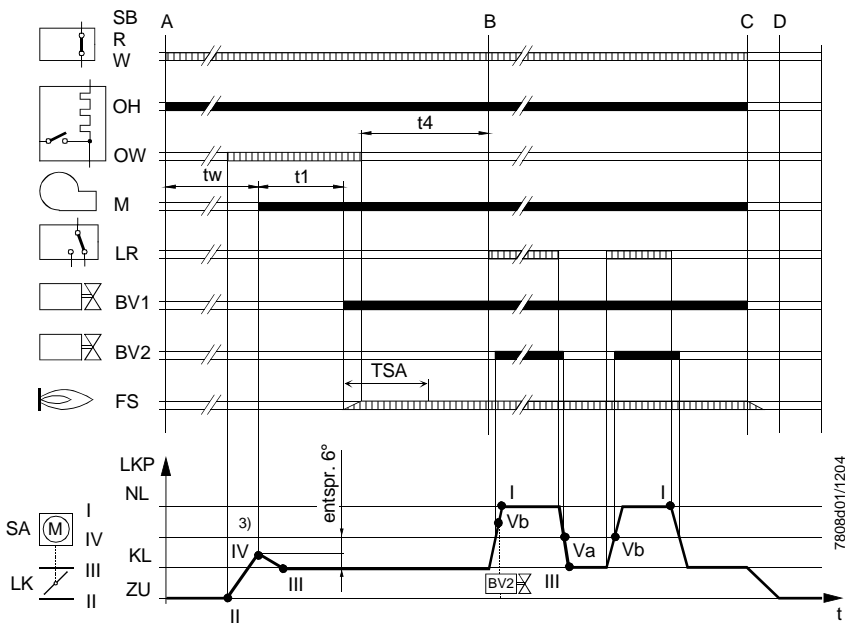

2-stage operation → Prepurging at low-fire position «KL»

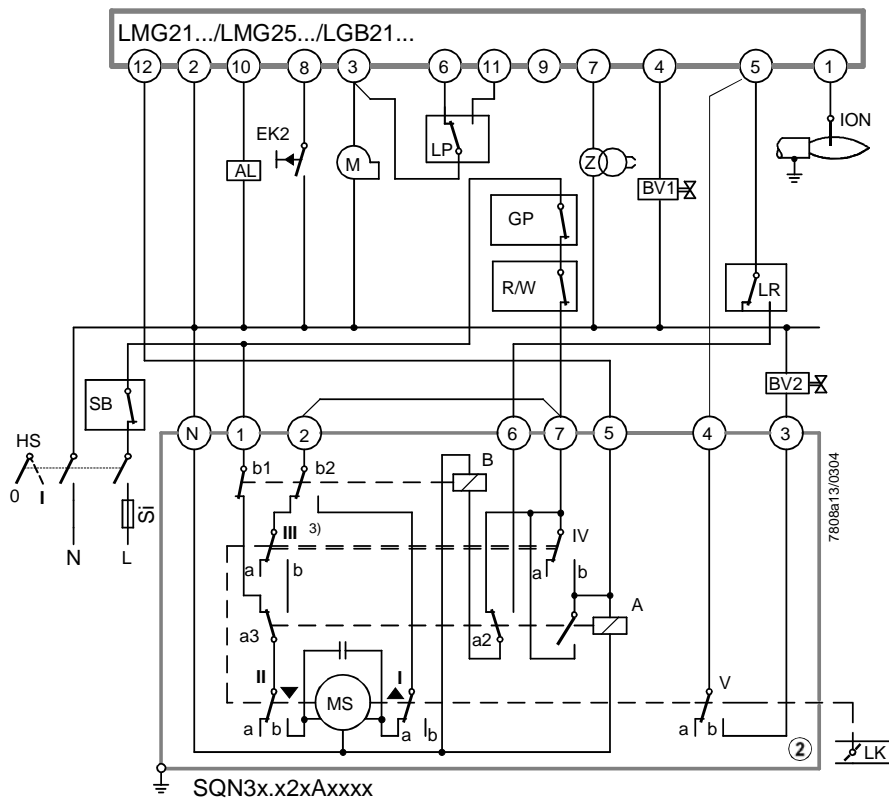

3) Cams III and IV are rigidly connected

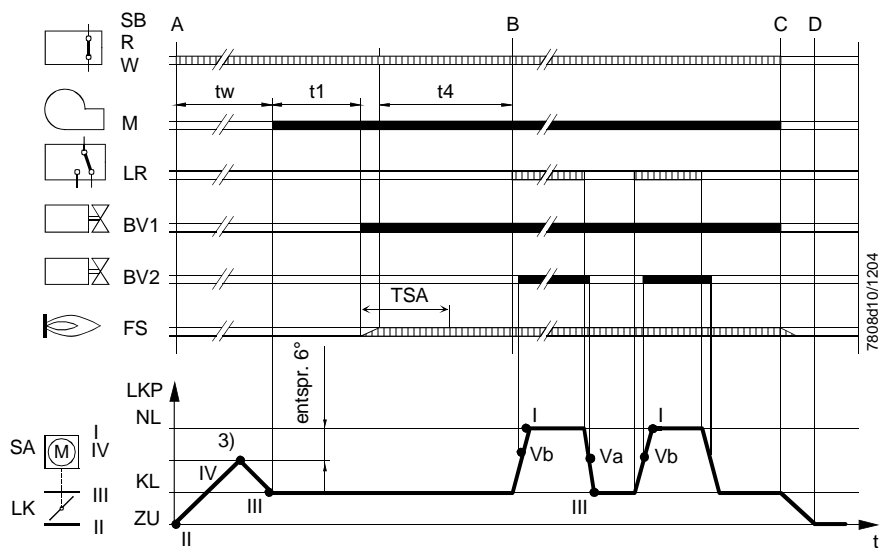

No. 5 → LMG22... / LGB22... / LGB32...

2-stage or modulating operation → Prepurging at nominal load position «NL»

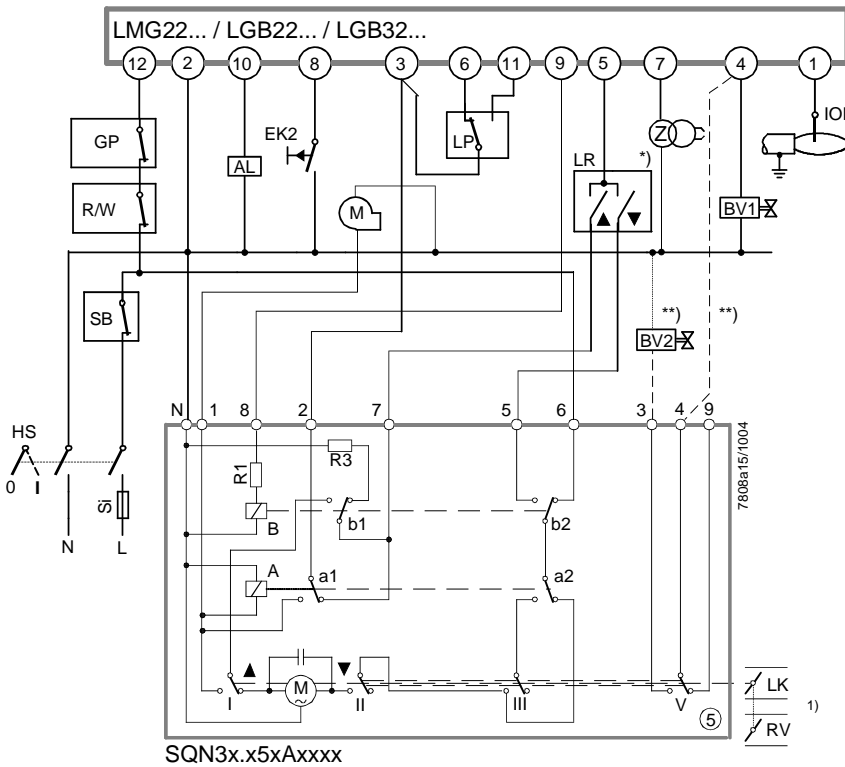

- 1) Diagram shows arrangement for modulating operation
- \*) Thermostat or similar with changeover contact (2-wire control) or 3-position controller for «on / off» positioning pulses and neutral position
- \*\*\*) In case of 2-stage modulating burners (with gas damper «RV»), «BV2» and the connection between the terminals (shown as a broken line) will not be needed

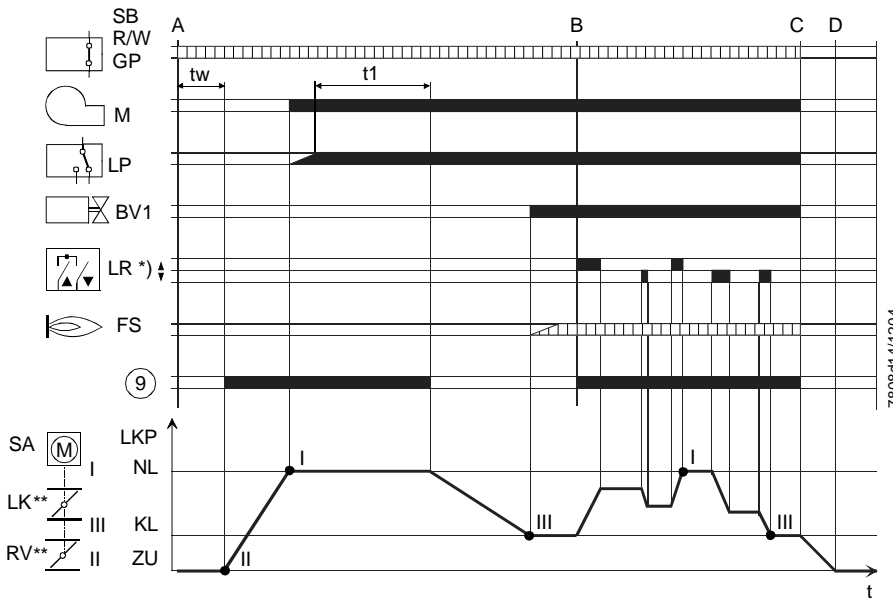

Program sequence diagram shows modulating operation

Modulating operation → Prepurging at nominal load position «NL»

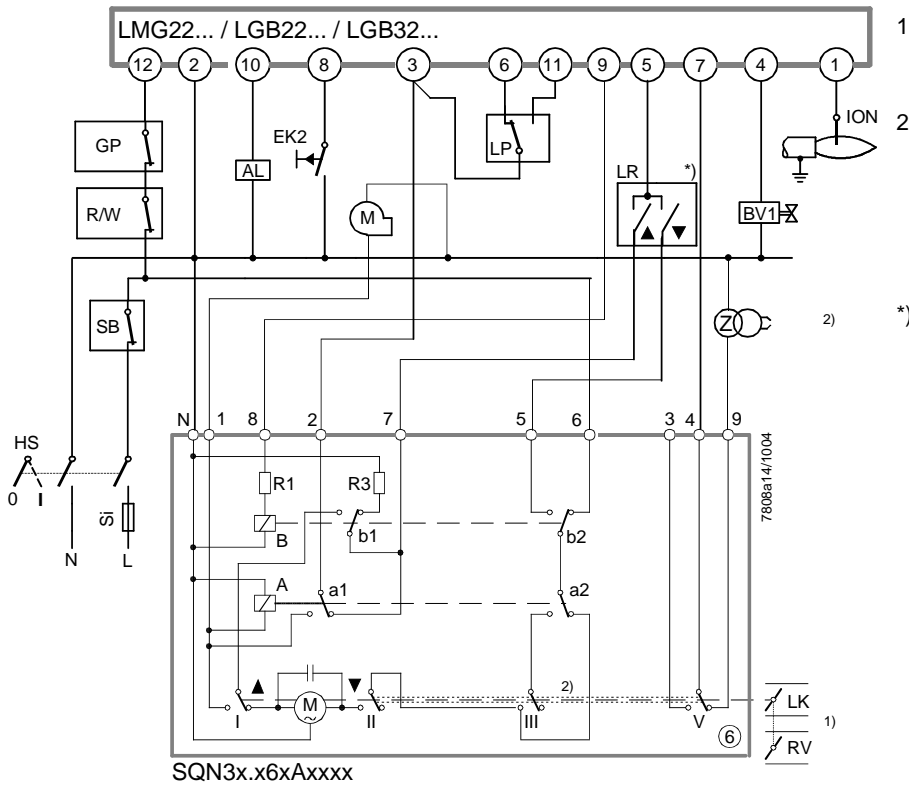

1) Diagram shows arrangement for modulating operation

2) The cams of switches III and V are rigidly connected. This ensures that ignition takes place at the low-fire position «KL»

\*) Thermostat or similar with changeover contact (2-wire control) or 3-position controller for «on / off» positioning pulses and neutral position

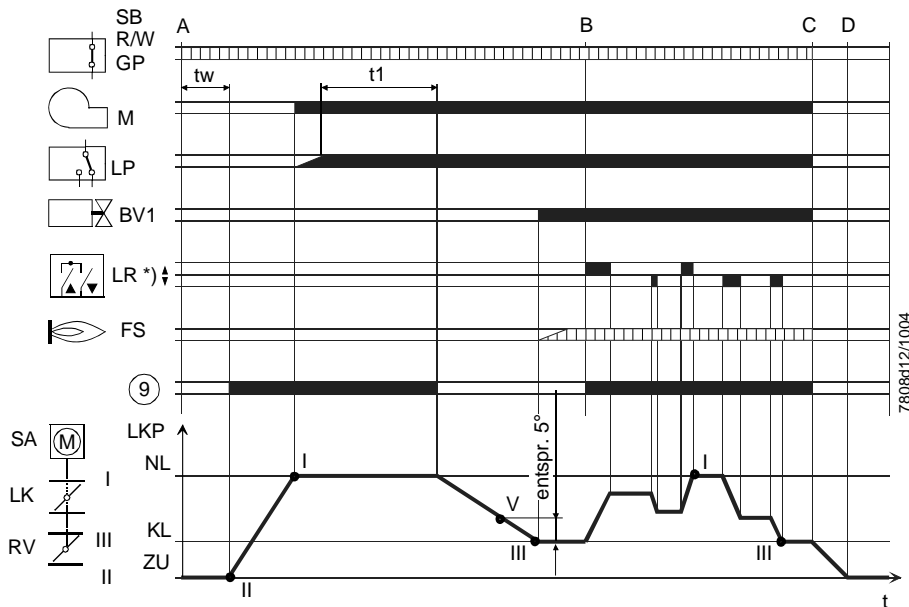

Program sequence diagram shows modulating operation



**Attention!**

If the contacts of switch V welded in position 4 → 9, supervision of the ignition load position would be negated and not be detected in operation. This means that the circuit is not safety-related but only used for supervision purposes. The user must ensure that in the event of failure (should the burner ignite at nominal load «NL»), no damage will occur.

Connection diagram (cont'd)

No. ④ → Special application

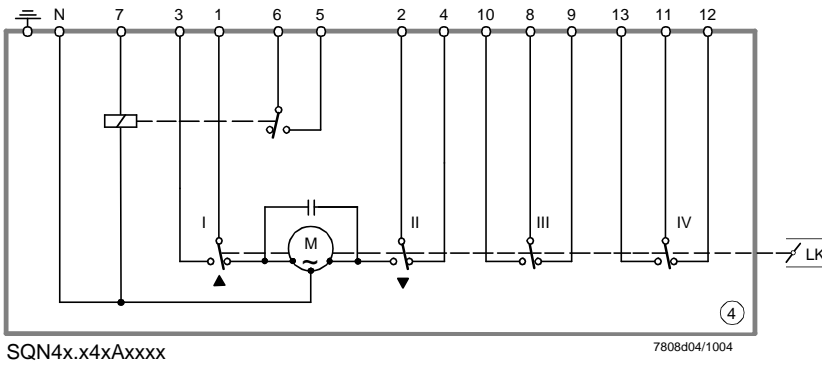

No. ③ → TMG740 / TMO720 (burner control of other manufacture)

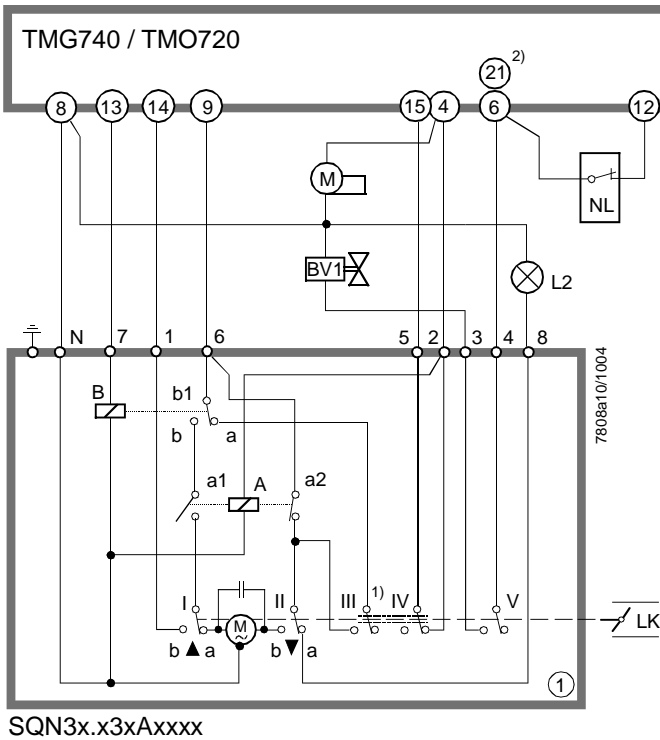

2-stage operation → Prepurging at nominal load position «NL»

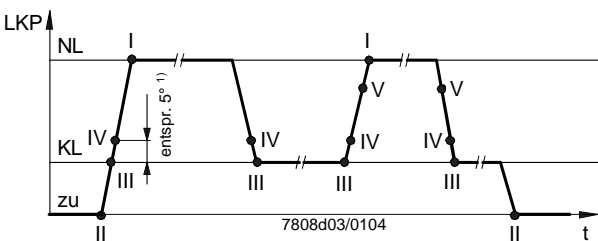

- 1) Cams of switches III and IV are rigidly connected
- 2) TMO720 terminal no. 6  
TMG740 terminal no. 21



- TMG... and TMO... are devices of other manufacture, neither made nor supplied by Siemens. Combination with the type of Siemens actuator proposed here must be checked with the supplier of the TMG... or TMO... while taking into consideration safety aspects and the current burner control version.  
The user assumes full responsibility for this application.

Legend	No. ②	Number of internal diagram (second position after the dot in the actuator's type reference)
	I / II	End switch
	III / IV / V	Auxiliary switch
	AL	Remote indication of fault (alarm)
	BV1	Fuel valve stage 1
	BV2	Fuel valve stage 2
	EK2	External remote reset button
	ION	Ionization probe
	FS	Flame signal amplifier
	GL	Gas / air ratio controller
	GP	Gas pressure switch
	HS	Main switch
	KL	Low-fire
	L	Live conductor
	LK	Air damper
	LKP	Air damper position
	LP	Air pressure switch
	LR	Load controller
	M	Burner or fan motor
	Ⓜ	Actuator's synchronous motor
	M1	Without postpurging
	M2	With postpurging
	N	Neutral conductor
	NL	Nominal load
	OH	Oil preheater
	OW	Oil preheater's readiness contact
	QRB...	Photoresistive flame detector
	R	Temperature or pressure controller
		Relay
	RV	Gas damper
	SA	Actuator
	Si	External primary fuse (as specified in the Data Sheet of the relevant burner control)
	SB	Safety limiter
	ST...	Stage
	t... / T...	Program times (refer to the Data Sheet of the relevant burner control)
	TSA	Safety time
		Resistance
	Z	Ignition transformer
	ZU	Damper fully closed
	▲	Direction of rotation OPEN
	▼	Direction of rotation CLOSE

#### Program sequence diagrams

A	Burner ON
A – B	Startup of burner
B – C	Burner operation / load control operation (modulating or 2-stage)
C	Burner OFF
C – D	Overrun time
D	End of program sequence, burner control ready for a new start



# Dimensions

Dimensions in mm

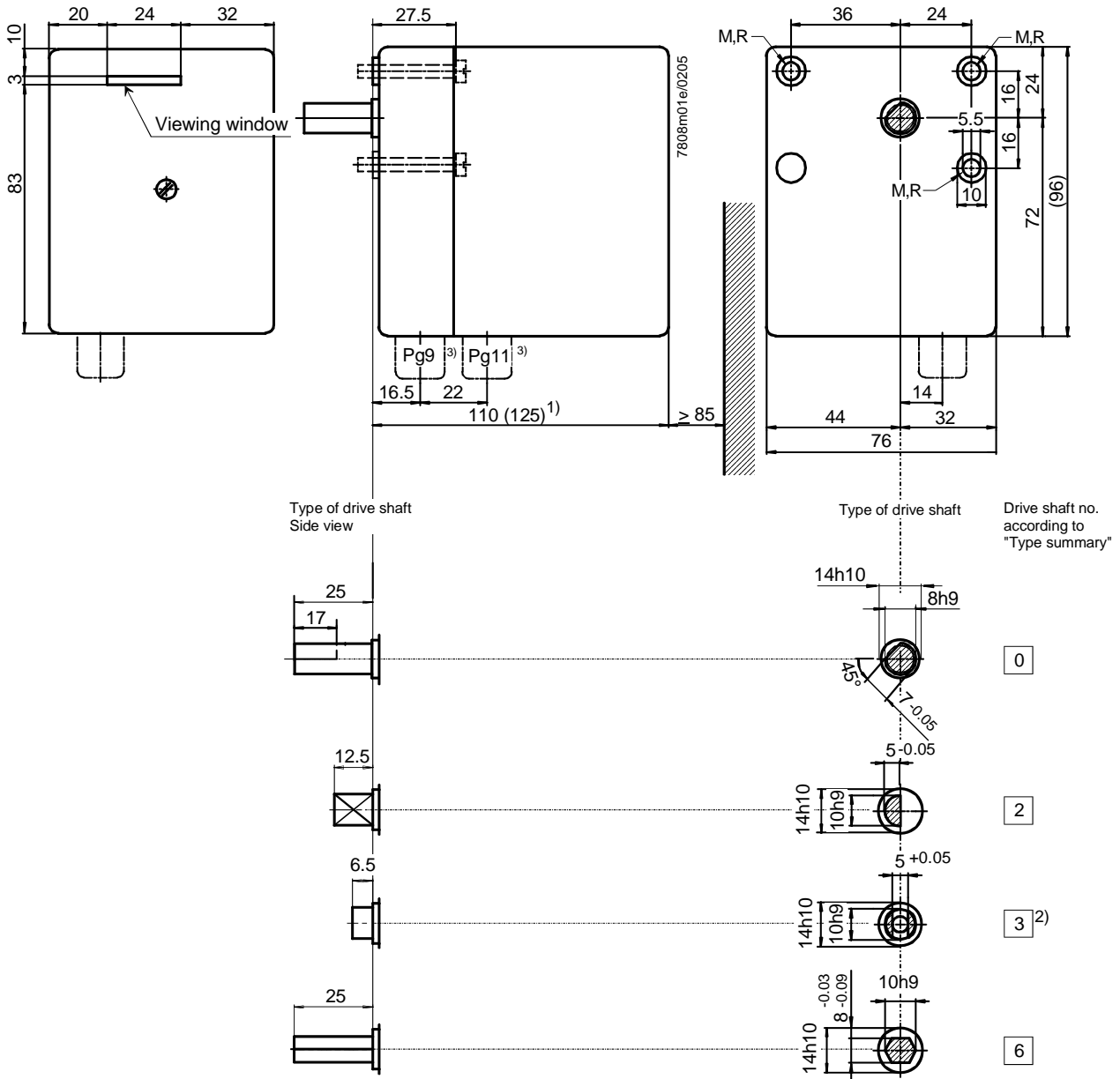

All drive shafts are shown in end switch position II (CLOSED, as supplied).

- 1) Housing length depending on type of actuator (refer to «Type summary»)
- 2) Center slot: 6.3 mm deep  
Hole dia. 5.1 mm: 16.5 mm deep (incl. center slot depth)
- 3) Not included in delivery

R Fixing positions  
M Through-hole 5.3 mm dia.